



## KHTEK DA1196 - Digital to Audio Converter

### *24Bit, 192KHz, 6-Channel*

## General Description

DA1196 is a digital to analog converter especially designed to work with MPEG2/AC-3 decoded data in applications such as, DVD player, home theater, set-top box, and digital TV, etc. DA1196 integrates 6 DA channels providing customers a solution of both simplicity and excellent performance.

## Features

### High Resolution:

- 16/18/20/24/32 Bit Selectable

### High Performance:

Sampling Rate: 8KHz ~ 192KHz

THD+N: -98 dB

Dynamic Range: 104dB

S/N Ratio: 104dB

Channel Separation: 107dB

### High Integration:

- 6 Audio Channels, each contains:
  - Oversampling Digital Filter
  - High-Resolution Delta Sigma DAC
  - Analog Low Pass Filter
  - Output Amplifier

### High Versatility

- Control via 3-Wire Interface or Hardware Pins
- Left/Right-justified or IIS Format Selectable
- Selectable De-emphasis Sampling Rate:
  - 32KHz, 44.1KHz, 48KHz
- Selectable Multiple Functions:
  - Soft Mute
  - Attenuation
  - De-emphasis
  - Zero Detection On/Off Control
- Selectable Output Operation Mode:
  - Left, Right, Stereo, Mono, or Mute

### 28 Pin SSOP Package

## Pin Configuration

1	VDD	VCC1	28
2	SCKI	VOUTR1	27
3	BCKIN	AGND	26
4	SRCIN	VOUTL1	25
5	DIN1	AGND1	24
6	DIN2	VOUTR2	23
7	DIN3	AGND	22
8	MODE	VOUTL2	21
9	MUTE	AGND2	20
10	NC	VOUTR3	19
11	DGND	AGND	18
12	ML/I2S	VOUTL3	17
13	MC/TWL	CAP	16
14	MD	VCC2	15

## Pin Assignments

Pin	Name	I/O	Description
1	VDD	PWR	Digital Power Supply
2	SCKI	IN	Crystal Oscillator Input or External Master/System Clock Input
3	BCKIN	IN	Bit Clock Input for Audio Data
4	SRCIN	IN	Sample Rate Clock Input
5	DIN1	IN	Audio Data Input to DAC1
6	DIN2	IN	Audio Data Input to DAC2
7	DIN3	IN	Audio Data Input to DAC3
8	MODE	IN	Mode Control, "0"= Software Mode; "1"= Hardware Mode.
9	MUTE	IN	Mute Control, Active "High". To Mute, Pull this Pin High.
10	NC		Not Connected (Don't Care)
11	DGND	GND	Digital Ground
12	ML/I2S	IN	Latch for Serial Control in Software Mode or Input Format Selection in Hardware Mode.
13	MC/IWL	IN	Clock for Serial Control Data in Software Mode or Input Word Length Selection in Hardware Mode.
14	MD	IN	Serial Control Data in Software Mode.
15	VCC2	PWR	Analog Power
16	CAP	-	Analog Common Mode Pin
17	VOU3L3	OUT	L-Channel Output from DAC3
18	AGND	GND	Analog Ground
19	VOU3R3	OUT	R-Channel Output from DAC3
20	AGND2	GND	Analog Ground
21	VOU2L2	OUT	L-Channel Output from DAC2
22	AGND	GND	Analog Ground
23	VOU2R2	OUT	R-Channel Output from DAC2
24	AGND1	GND	Analog Ground
25	VOU1L1	OUT	L-Channel Output from DAC1
26	AGND	GND	Analog Ground
27	VOU1R1	OUT	R-Channel Output from DAC1
28	VCC1	PWR	Analog Power

Note:

- All digital input pins have Schmitt triggers and internal pull-up resistors except the SCKI pin and MUTE pin, which have internal pull-down resistors.
- Logic high is denoted as either "H" or "1"; logic low is denoted as either "L" or "0" in this document.

## Absolute Maximum Rating

Power Supply Voltage	+ 6.5V
+VCC to VDD Difference	+/- 0.1V
Input Logic Voltage	-0.3V to (VDD + 0.3V)
Power Dissipation	600mW
Operating Temperature Range	-25 C to +85 C
Storage Temperature	-55 C to +125 C



### ESD Sensitive Device

Although DA1196 is furnished with KHTEK's proprietary ESD protection circuitry, proper ESD precaution is still recommended to avoid performance degradation or permanent damage.

## Package Information

Model	Package	Package Drawing No.
DA1196	28 pin SSOP	128 -SS

Package drawing is at the end of this data sheet

# Specifications

## Electrical Characteristics:

At 25 °C, VCC1=VCC2=VDD=5V/3.3V, fs=48kHz, 24Bit input data, System Clock = 384/256fs.

Parameter	Conditions	Min	Type	Max	Unit
Sampling Frequency		8	48	192	KHz
System Clock Frequency	128fs	1.024	6.144	24.5760	MHz
	192fs	1.536	9.216	36.8640	MHz
	256fs	2.048	12.288	49.1520	MHz
	384fs	3.072	18.432	73.7280	MHz
	512fs	4.096	24.576		MHz
	768fs	6.144	36.864		MHz
Audio Data Format	Selectable		Right/ Left/I <sup>2</sup> S		
Data Bit Length	Selectable		16/20/24/32		Bits
<b>Power Supply</b>					
Voltage Range: VCC1, VCC2, VDD	VCC1=VCC2=VDD=5V	4.5	5	5.5	V
	VCC1=VCC2=VDD=3.3V	3.0	3.3	3.7	V
@fs=44.1KHz					
Supply Current: ICC1+ICC2+IDD	VCC1=VCC2=VDD=5V		68		mA
	VCC1=VCC2=VDD=3.3V		43		mA
Power Dissipation:	VCC1=VCC2=VDD=5V		340		mW
	VCC1=VCC2=VDD=3.3V		142		mW
@fs=96KHz					
Supply Current: ICC1+ICC2+IDD	VCC1=VCC2=VDD=5V		75		mA
	VCC1=VCC2=VDD=3.3V		48		mA
Power Dissipation:	VCC1=VCC2=VDD=5V		375		mW
	VCC1=VCC2=VDD=3.3V		158		mW
<b>Digital Input/Output</b>					
<b>Input Logic Level</b>	VCC1=VCC2=VDD				
V <sub>IH</sub>	Pin2	40%			VDD
V <sub>IL</sub>				16%	VDD
V <sub>IH</sub>	Pin 3,4,5,6,7,8,9,12,13,14	52%			VDD
V <sub>IL</sub>	---Schmitt Trigger			16%	VDD
<b>Output Logic Level</b>	VCC1=VCC2=VDD				
V <sub>OH</sub>		90%			VDD
V <sub>OL</sub>				10%	VDD
<b>DC Accuracy</b>					
Gain Error			+/- 1	+/- 3	%FSR
Gain Mismatch Ch to Ch			+/- 1	+/- 2	%FSR
<b>Analog Output</b>			VCC, VDD		
Voltage Range	V <sub>out</sub> =0dB		5V	3.3V	
			1.0	0.66	
			2.5	1.65	
Center Voltage					V <sub>rms</sub>
Load Impedance	AC Load	10			KOhm
Frequency Response		0		20	KHz

**Electrical Characteristics:(Cont.)**

At 25 °C, VCC1=VCC2=VDD=5V/3.3V, fs=48kHz, 24Bit input data, System Clock = 384/256fs.

Parameter	Conditions	Min	Type		Max	Unit
			VCC	VDD		
<b>Dynamic Performance</b>						
			5V	3.3V		
@fs=48KHz						
THD+N at FS(0dB)	Fout=1kHz		-98	-97	-100	dB
THD+N at -60dB	Fout=1kHz		-44	-42	-46	dB
Dynamic Range	EIAJ, A-weighted	100	104	102	106	dB
SNR	EIAJ, A-weighted	100	104	102	106	dB
Channel Separation	Fout=1kHz	105	107	105	110	dB
@fs=96KHz						
THD+N at FS(0dB)	Fout=1kHz		-98	-97	-100	dB
THD+N at -60dB	Fout=1kHz		-43	-41	-45	dB
Dynamic Range	EIAJ, A-weighted	98	103	101	105	dB
SNR	EIAJ, A-weighted	98	103	101	105	dB
Channel Separation	Fout=1kHz	103	105	103	108	dB
@fs=192KHz						
THD+N at FS(0dB)	Fout=1kHz		-97	-96	-100	dB
THD+N at -60dB	Fout=1kHz		-42	-39	-43	dB
Dynamic Range	EIAJ, A-weighted	98	102	99	103	dB
SNR	EIAJ, A-weighted	98	102	99	103	dB
Channel Separation	Fout=1kHz	100	102	100	105	dB

**Timing Characteristics:**

**SCKI/Master Clock Input Timing:**

**Timing Parameter**

Parameter	Symbol	Value	Unit
<b>Master Clock Timing</b>			
SCKI clock high level	SCKIH	>10	ns
SCKI clock low level	SCKIL	>10	ns

At 25°C, VCC=VDD=5V/3.3V, fs=48kHz, 24Bit input data, System Clock = 384/256fs

**Timing Diagram**

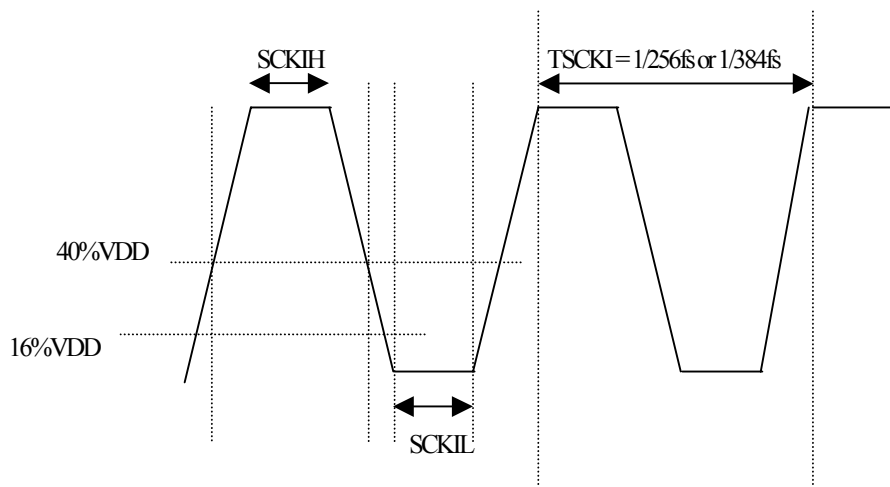

**Timing Parameter:**

Parameter	Symbol	Value	Unit
Data Input Timing			
DIN setup time	tds	>30	ns
DIN hold time	tdh	>30	ns
BCKIN high-level, low-level	tbcwh, tbcwl	>50	ns
BCKIN pulse cycle time	tbcy	>100	ns
BCKIN rising edge to SRCIN	tbsr	>30	ns
SRCIN to BCKIN rising edge	tsrb	>30	ns

At 25°C, VCC=VDD=5V/3.3V, fs=48kHz, 24Bit input data, System Clock = 384/256fs

**Timing Diagram**

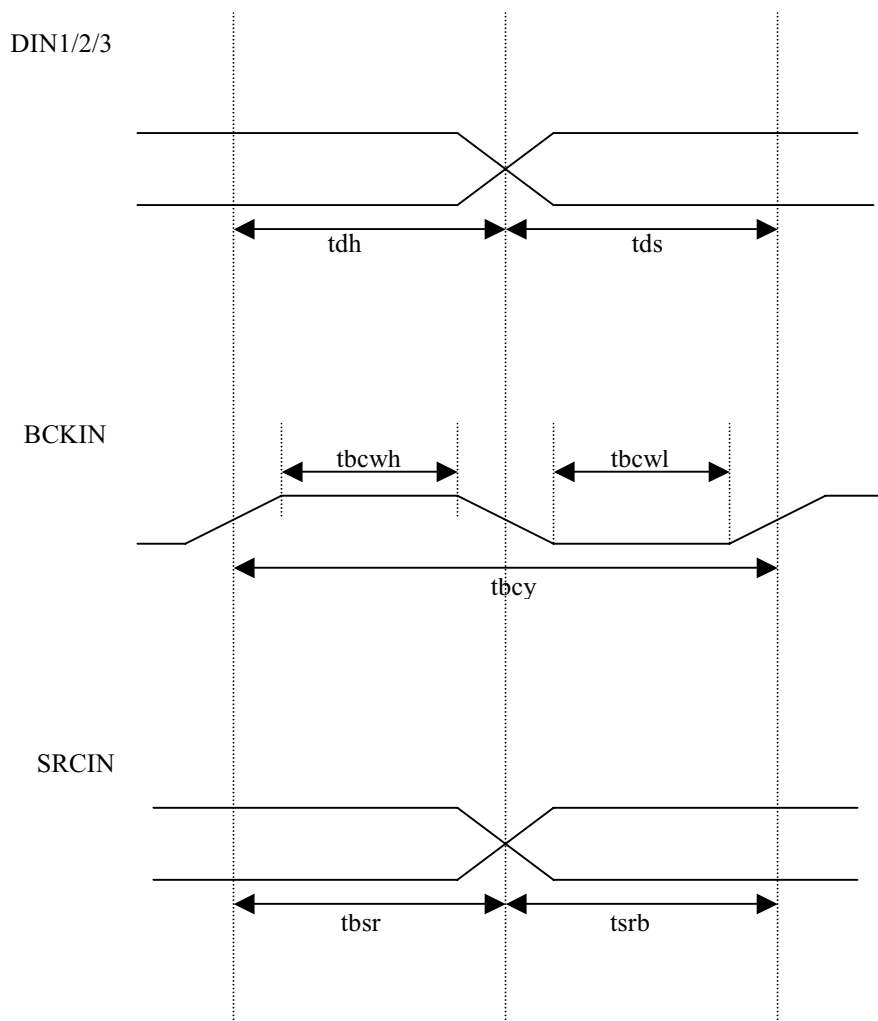

**3 Wire Serial Mode Control Timing:**

**Timing Parameter:**

Parameter	Symbol	Value	Unit
Serial Mode Control Timing			
MC pulse high-level, low-level	tmcwh, tmcwl	>50	ns
MC pulse cycle time	tmcy	>100	ns
MD setup time	tmds	>30	ns
MD hold time	tmdh	>30	ns
ML setup time	tmcs	>30	ns
ML hold time	tmch	>30	ns
ML pulsewidth high-level, low-level	tmlwh, tmlwl	>30+1/fs	ns

At 25°C, VCC=VDD=5V/3.3V, fs=48kHz, 24Bit input data, System Clock = 384/256fs

**Timing Diagram**

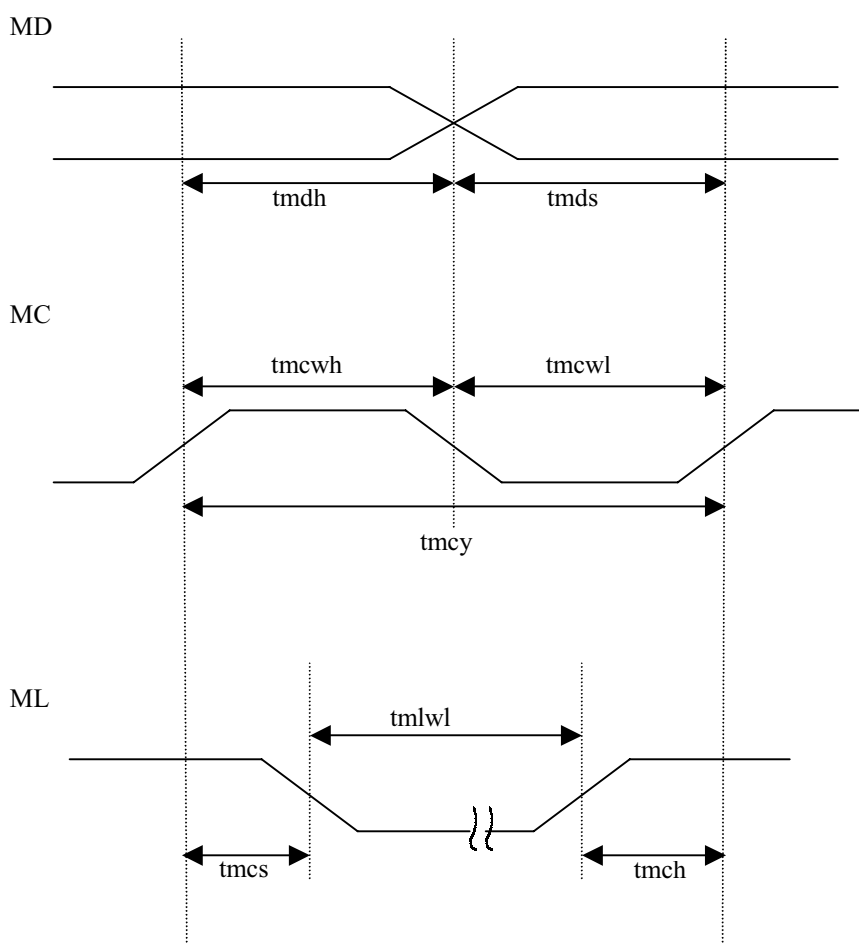

# Functional Description

## Functional Block Diagram

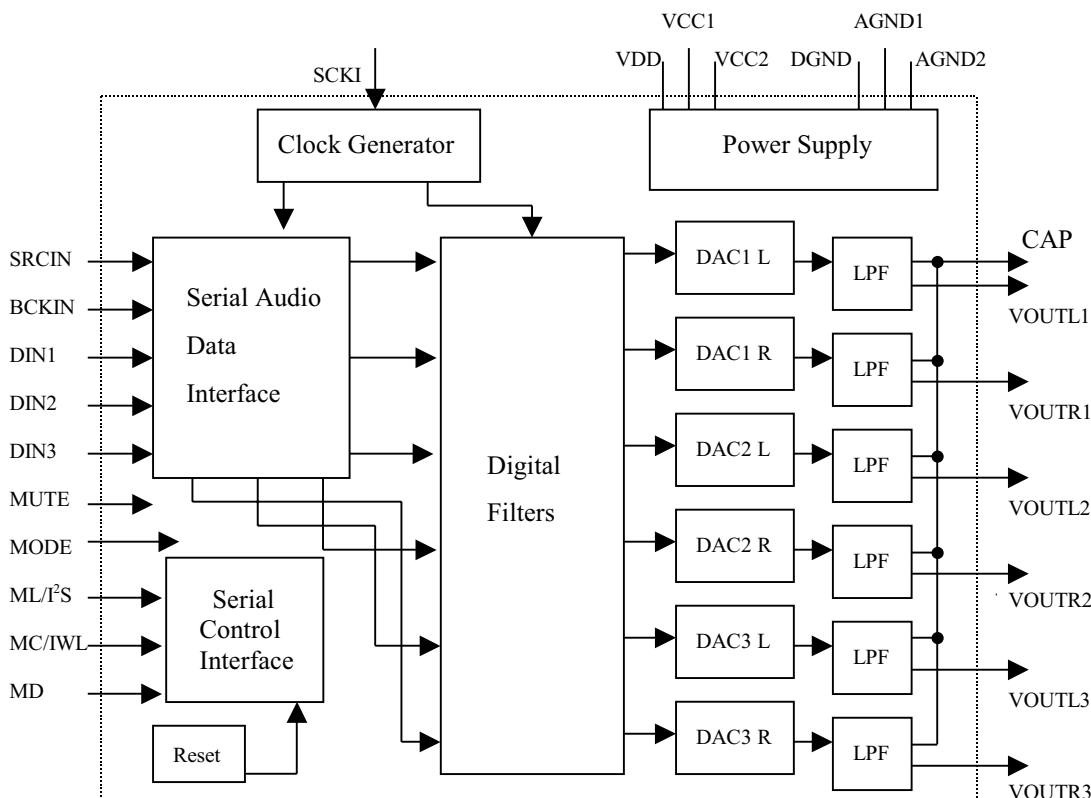

## System Clock

The system clock must be 128fs, 192fs, 256fs, 384fs, 512fs, or 768fs, where fs is the standard audio frequency including 32KHz, 44.1KHz, 48KHz, 96KHz, or 192KHz. The system clock can be input via SCKI (pin2) from an external clock and is used to operate the digital filter and delta sigma modulator. The system clock should be synchronized with SRCIN (pin4) – sampling rate clock. If the phase difference between them becomes greater than 6 bit BCKIN (pin3), the synchronization will be automatically performed and at this time the analog outputs are forced to VCC/2 by the chip.

**Table-1 System Clock and Sampling Rate**

Sampling Rate fs	System Clock Frequency (MHz)					
	128 fs	192 fs	256fs	384fs	512fs	768fs
32KHz	4.0960	6.1440	8.1920	12.2880	16.3840 <sup>(1)</sup>	24.5760 <sup>(1)</sup>
44.1KHz	5.6448	8.4670	11.2896	16.9340	22.5792 <sup>(1)</sup>	33.8688 <sup>(1)</sup>
48KHz	6.1440	9.2160	12.2880	18.4320	24.5760 <sup>(1)</sup>	36.8640 <sup>(1)</sup>
96KHz	12.2880	18.4320	24.5760	36.8640	49.1520 <sup>(1)</sup>	73.7280 <sup>(1)</sup>
192KHz	24.5760	36.8640	49.1520 <sup>(1)</sup>	73.7280 <sup>(1)</sup>	98.3040 <sup>(2)</sup>	147.456 <sup>(2)</sup>

(1) For these sampling rate and system clock conditions, the SC1 bit of **Reg9** should be set to “0”; and the SC0 bit of **Reg9** should be set to “1”.

(2) For these sampling rate and system clock conditions, the SC1 bit of **Reg9** should be set to “1”; and the SC0 bit of **Reg9** should be set to “1”.

### Serial Digital Audio Data Input Interface

The digital audio information is applied to DA1196 via DIN1/2/3 (pin 5, 6, 7) for audio data input, via SRCIN (pin 4) for sampling rate clock, and via BCKIN (pin 3) for bit clock. The DA1196 supports right justified, left justified, and I<sup>2</sup>S data formats. All data formats are MSB first and two's complement. Both left justified format and I<sup>2</sup>S format support word length from 16 Bit to 32 Bit, but the right justified format supports word length only up to 24 Bit. The I<sup>2</sup>S data format, which is compatible with Philips serial data protocol, is left justified and one bit clock delay between SRCIN and data MSB. The relationship of the three audio input signals, DIN, SRCIN, and BCKIN is illustrated in the following figures for three formats:

#### Right Justified Format

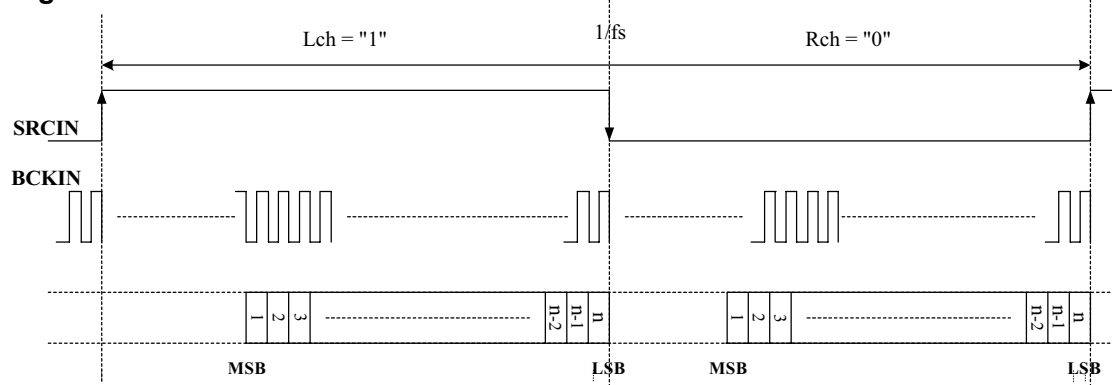

#### Left Justified Format

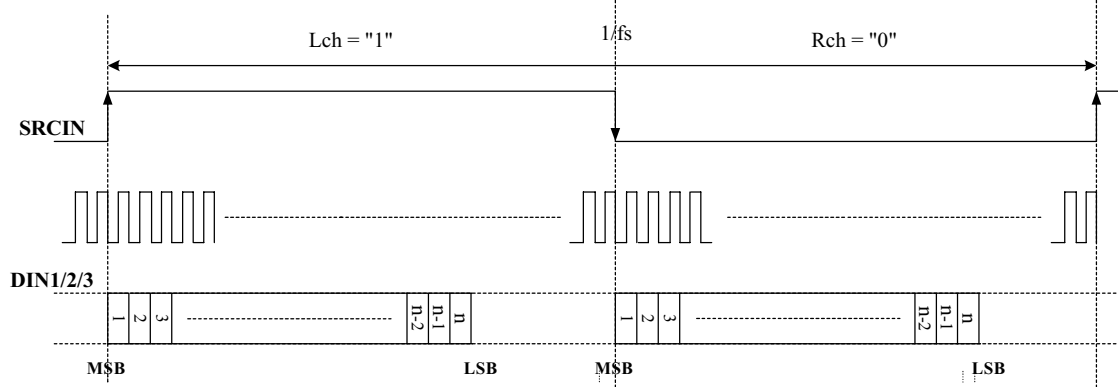

#### I<sup>2</sup>S Format

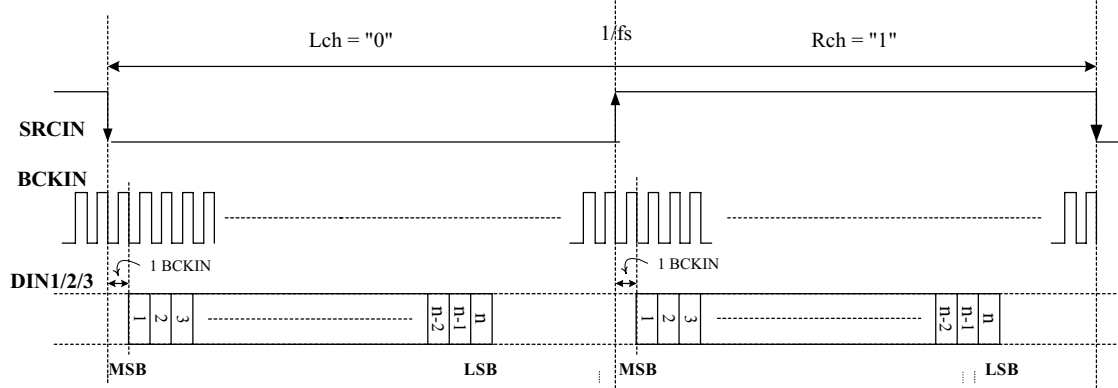

Note: 1. Logic high is denoted as either "H" or "1"; logic low is denoted as either "L" or "0" in this document.

2. With IIS format, the word length can go up to 32 Bit as long as the SRCIN period can accommodate.



## Multi-Functions & Mode Control

DA1196 can operate in two different control modes – serial (software) or parallel (hardware). Which mode to operate is selected by MODE pin (pin8) and is illustrated in following table:

**Table-2 Serial/Parallel Selection**

MODE (pin8)	Selected Mode	Selected Pins
Low	Serial (or Software) Mode	MD (pin14), MC (pin13), ML (pin12)
High	Parallel (or Hardware) Mode	IWL (pin13), I2S (pin12)

### Hardware (Parallel) Mode Control, MODE="1"

When MODE pin (pin8) is set to "1", DA1196 is in hardware mode; the logic levels set on the hardware pins – pin9, pin12, pin13, and pin14 control a few functions implemented in the DA1196 for hardware mode.

A logic "0" on MUTE pin (pin 9) allows for a normal operation; but a logic "1" on MUTE pin (pin9) would force the outputs to be soft muted.

**Table-3 Selectable Mute Function**

MUTE (pin 9)	Mute Function
0	OFF
1	ON

I<sup>2</sup>S (pin12) and IWL (pin13) together can be used to obtain different input data format and word length. The proper settings are shown in the following table:

**Table-4 Selectable Input Data Formats**

Input Data Format	I <sup>2</sup> S (pin12)	IWL (pin13)
Normal Format -16Bit	0	0
Normal Format -20Bit	0	1
Normal Format -24Bit	1	0
I <sup>2</sup> S	1	1

The De-emphasis function is not available in hardware mode. That is, in hardware mode the MD (pin14) becomes a NC pin and can be connected either to ground or power.

**Table-5 De-emphasis Function**

MD (pin14)	De-emphasis
0	OFF
1	OFF

DA1196 provides several built-in functions in software (serial) mode, such as digital attenuation, de-emphasis, output control, and soft mute. Following **Table-6** shows the selectable functions and their default conditions:

**Table-6 Selectable Functions**

Function	Selections	Default
Digital Audio Input Format Selection	Right Justified, Left Justified, or I <sup>2</sup> S	Right Justified
Input Audio Data Word Length	16-bit, 20-bit, 24-bit, or 32-bit	24bit
BCKIN Polarity Selection	Sample on Rising Edge or Falling Edge	On Rising Edge
Digital Attenuation for each channel	0dB ~ Mute	0dB
Master Digital Attenuation of all channels	0dB ~ Mute	0dB
Soft Mute Control	ON or OFF	OFF
De-emphasis Control	ON or OFF	OFF
De-emphasis Sample Rate Selection	OFF, 32KHz, 48kHz , or 44.1KHz	OFF
Modulator Over-sampling Selection	32X, 64X, or 128X	64X
Analog Output Control	L, R, Mono, Stereo, or Mute	Stereo
Analog Output Reverse Control	OUT1L/R, OUT2L/R, OUT3L/R, or OUT1R/L, OUT2R/L, OUT3R/L	OUTXL/R X=1, 2, 3
DAC Operation Control	Operate or Disabled	Operated
Infinite Zero Detection Control	Enabled or Disabled	Not Detected

These implemented functions are controlled via a 3-wire serial interface, namely, MD (pin14) is input pin for control data, MC (pin13) is input pin for control clock, and ML (pin12) is for control latch.

**Control Data Input**

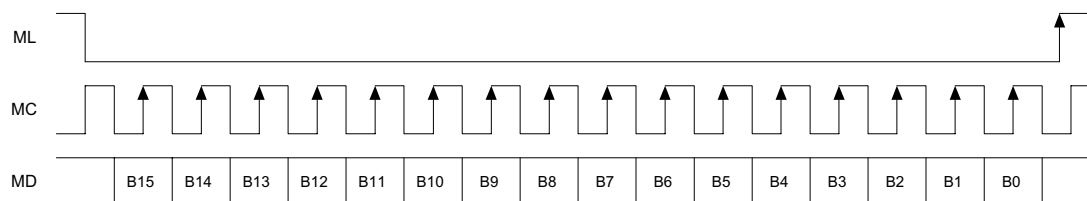

The chip has ten 16-bit internal registers for programming and shown as below. In order to use all the built-in functions that DA1196 provides, the ten registers must be addressed via the three -wire interface using MD (pin 14), MC (pin 13), and ML (pin 12) ten separate times to set all desired register values.

**Ten Internal Registers**

Reg	B15	B14	B13	B12	B11	B10	B9	B8	B7	B6	B5	B4	B3	B2	B1	B0
0	Res	Res	Res	A3	A2	A1	A0	LDL1	L1A7	L1A6	L1A5	L1A4	L1A3	L1A2	L1A1	L1A0
1	Res	Res	Res	A3	A2	A1	A0	LDR1	R1A7	R1A6	R1A5	R1A4	R1A3	R1A2	R1A1	R1A0
2	Res	Res	Res	A3	A2	A1	A0	PL3	PL2	PL1	PL0	IZD	ATC	OPE	DEM	MUT
3	Res	Res	Res	A3	A2	A1	A0	PRV2	PRV1	PRV0	IW1	IW0	BCP	Res	FM1	FM0
4	Res	Res	Res	A3	A2	A1	A0	LDL2	L2A7	L2A6	L2A5	L2A4	L2A3	L2A2	L2A1	L2A0
5	Res	Res	Res	A3	A2	A1	A0	LDR2	R2A7	R2A6	R2A5	R2A4	R2A3	R2A2	R2A1	R2A0
6	Res	Res	Res	A3	A2	A1	A0	LDL3	L3A7	L3A6	L3A5	L3A4	L3A3	L3A2	L3A1	L3A0
7	Res	Res	Res	A3	A2	A1	A0	LDR3	R3A7	R3A6	R3A5	R3A4	R3A3	R3A2	R3A1	R3A0
8	Res	Res	Res	A3	A2	A1	A0	LDS	SA7	SA6	SA5	SA4	SA3	SA2	SA1	SA0
9	Res	Res	Res	A3	A2	A1	A0	Res	Res	SC1	SC0	Res	SF1	SF0	MC1	MC0

Following Table-7 describes in detail the functions controlled by each register bit:

**Table-7 Register Mapping**

Register name		Function																																																																																																						
<b>Reg0</b>		Attenuation Control of DAC1 Left Channel																																																																																																						
<b>B12~B9</b>	A3, A2, A1, A0	Register Address. To access <b>Reg0</b> , set A3="0", A2="0", A1="0", A0="0".																																																																																																						
<b>B8</b>	LDL1	<u>DAC1 Left Channel Attenuation Data Load Control.</u> When LDL1="0", the attenuation data L1A7~L1A0 are loaded but do not affect the output level until LDL1="1". That is when LDL1="0", the left channel output level remains at the previous attenuation level; and when LDL1="1", the left channel output level becomes affected by L1A7~L1A0. Either LDL1 or LDR1 is set to "1", the L and R channel attenuation data become effective simultaneously.																																																																																																						
<b>B7~B0</b>	L1A7~L1A0	<u>DAC1 Left Channel Attenuation Data.</u> Attenuation level = $20 \cdot \log(L1A[7:0]/256)$ dB.																																																																																																						
<b>Reg1</b>		Attenuation Control of DAC1 Right Channel																																																																																																						
<b>B12~B9</b>	A3, A2, A1, A0	Register Address. To access <b>Reg1</b> , set A3="0", A2="0", A1="0", A0="1".																																																																																																						
<b>B8</b>	LDR1	<u>DAC1 Right Channel Attenuation Data Load Control.</u> When LDR1="0", the attenuation data R1A7~R1A0 are loaded but do not affect the output level until LDR1="1". That is when LDR1="0", the right channel output level remains at the previous attenuation level; and when LDR1="1", the right channel output level becomes affected by R1A7~R1A0. Either LDL1 or LDR1 is set to "1", the L and R channel attenuation data become effective simultaneously.																																																																																																						
<b>B7~B0</b>	R1A7~R1A0	<u>DAC1 Right Channel Attenuation Data.</u> Attenuation level = $20 \cdot \log(R1A[7:0]/256)$ dB.																																																																																																						
<b>Reg2</b>		DAC Multi-function Control																																																																																																						
<b>B12~B9</b>	A3, A2, A1, A0	Register Address. To access <b>Reg2</b> , set A3="0", A2="0", A1="1", A0="0".																																																																																																						
<b>B8~B5</b>	PL3 ~ PL0	<u>Analog Output Mode Selection.</u> <table border="1"> <thead> <tr> <th>PL3</th> <th>PL2</th> <th>PL1</th> <th>PL0</th> <th>Lch (pin17, 21, 25)</th> <th>Rch (pin19, 23, 27)</th> </tr> </thead> <tbody> <tr><td>0</td><td>0</td><td>0</td><td>0</td><td>Mute</td><td>Mute</td></tr> <tr><td>0</td><td>0</td><td>0</td><td>1</td><td>L</td><td>Mute</td></tr> <tr><td>0</td><td>0</td><td>1</td><td>0</td><td>R</td><td>Mute</td></tr> <tr><td>0</td><td>0</td><td>1</td><td>1</td><td>(L+R)/2</td><td>Mute</td></tr> <tr><td>0</td><td>1</td><td>0</td><td>0</td><td>Mute</td><td>L</td></tr> <tr><td>0</td><td>1</td><td>0</td><td>1</td><td>L</td><td>L</td></tr> <tr><td>0</td><td>1</td><td>1</td><td>0</td><td>R</td><td>L</td></tr> <tr><td>0</td><td>1</td><td>1</td><td>1</td><td>(L+R)/2</td><td>L</td></tr> <tr><td>1</td><td>0</td><td>0</td><td>0</td><td>Mute</td><td>R</td></tr> <tr><td>1</td><td>0</td><td>0</td><td>1</td><td>L</td><td>R</td></tr> <tr><td>1</td><td>0</td><td>1</td><td>0</td><td>R</td><td>R</td></tr> <tr><td>1</td><td>0</td><td>1</td><td>1</td><td>(L+R)/2</td><td>R</td></tr> <tr><td>1</td><td>1</td><td>0</td><td>0</td><td>Mute</td><td>(L+R)/2</td></tr> <tr><td>1</td><td>1</td><td>0</td><td>1</td><td>L</td><td>(L+R)/2</td></tr> <tr><td>1</td><td>1</td><td>1</td><td>0</td><td>R</td><td>(L+R)/2</td></tr> <tr><td>1</td><td>1</td><td>1</td><td>1</td><td>(L+R)/2</td><td>(L+R)/2</td></tr> </tbody> </table>	PL3	PL2	PL1	PL0	Lch (pin17, 21, 25)	Rch (pin19, 23, 27)	0	0	0	0	Mute	Mute	0	0	0	1	L	Mute	0	0	1	0	R	Mute	0	0	1	1	(L+R)/2	Mute	0	1	0	0	Mute	L	0	1	0	1	L	L	0	1	1	0	R	L	0	1	1	1	(L+R)/2	L	1	0	0	0	Mute	R	1	0	0	1	L	R	1	0	1	0	R	R	1	0	1	1	(L+R)/2	R	1	1	0	0	Mute	(L+R)/2	1	1	0	1	L	(L+R)/2	1	1	1	0	R	(L+R)/2	1	1	1	1	(L+R)/2	(L+R)/2
PL3	PL2	PL1	PL0	Lch (pin17, 21, 25)	Rch (pin19, 23, 27)																																																																																																			
0	0	0	0	Mute	Mute																																																																																																			
0	0	0	1	L	Mute																																																																																																			
0	0	1	0	R	Mute																																																																																																			
0	0	1	1	(L+R)/2	Mute																																																																																																			
0	1	0	0	Mute	L																																																																																																			
0	1	0	1	L	L																																																																																																			
0	1	1	0	R	L																																																																																																			
0	1	1	1	(L+R)/2	L																																																																																																			
1	0	0	0	Mute	R																																																																																																			
1	0	0	1	L	R																																																																																																			
1	0	1	0	R	R																																																																																																			
1	0	1	1	(L+R)/2	R																																																																																																			
1	1	0	0	Mute	(L+R)/2																																																																																																			
1	1	0	1	L	(L+R)/2																																																																																																			
1	1	1	0	R	(L+R)/2																																																																																																			
1	1	1	1	(L+R)/2	(L+R)/2																																																																																																			
<b>B4</b>	IZD	<u>Internal Zero Detection Circuit Control.</u> IZD="1" function enabled; IZD="0" disabled.																																																																																																						
<b>B3</b>	ATC	<u>Attenuator Control.</u> When ATC="1", L1A[7:0] in <b>Reg0</b> , L2A[7:0] in <b>Reg4</b> , and L3A[7:0] in <b>Reg6</b> are used as a common attenuation data for both left and right channels in DAC1, DAC2, and DAC3 respectively; and R1A[7:0] in <b>Reg1</b> , R2A[7:0] in <b>Reg5</b> , R3A[7:0] in <b>Reg7</b> are ignored. When ATC="0", L1A[7:0] in <b>Reg0</b> , L2A[7:0] in <b>Reg4</b> , and L3A[7:0] in <b>Reg6</b> are used as the attenuation data for left channels of DAC1, DAC2, and DAC3; and R1A[7:0] in <b>Reg1</b> , R2A[7:0] in <b>Reg5</b> , and R3A[7:0] in <b>Reg7</b> are for right channels of DAC1, DAC2, and DAC3.																																																																																																						

<b>B2</b>	OPE	<u>Left and Right DAC Operation Control</u> When OPE="0", the device is in normal operation; when OPE="1", outputs are forced to VCC/2 and all registers hold at the present states.						
<b>B1</b>	DEM	<u>De-emphasis Control.</u> DEM="0", de-emphasis OFF; DEM="1", de-emphasis ON.						
<b>B0</b>	MUT	<u>Left and Right Soft Mute.</u> MUT="0", Mute OFF; MUT="1", Mute ON.						
<b>Reg3</b>		DAC Interface Control						
<b>B12~B9</b>	A3, A2, A1, A0	<u>Register Address.</u> To access <b>Reg3</b> , set A3="0", A2="0", A1="1", A0="1".						
<b>B8~B6</b>	PRV2~PRV0	<u>Analog Output Phase Control.</u>						
			DAC1 L	DAC1 R	DAC2 L	DAC2 R	DAC3 L	DAC3 R
	PRV2	0	-	-	-	-	-	-
	PRV2	1	-	-	-	-	Reverse	Reverse
	PRV1	0	-	-	-	-	-	-
	PRV1	1	-	-	Reverse	Reverse	-	-
	PRV0	0	-	-	-	-	-	-
	PRV0	1	Reverse	Reverse	-	-	-	-
<b>B5~B4</b>	IW1,IW0	<u>Input Word Length Selection.</u>						
		IW1	IW0	Input Word Length				
		0	0	16 bit				
		0	1	20 bit				
		1	0	24 bit				
		1	1	32 bit				
<b>B3</b>	BCP	<u>Bit Clock Polarity Selection</u> When BCP="0", audio input data is sampled on the rising edge of BCKIN; when BCP="1", audio input data is sampled on the falling edge of BCKIN.						
<b>B2</b>	Res	Reserved and should be set to "0".						
<b>B1~B0</b>	FM1~FM0	<u>Audio Data Format Selection.</u>						
		FM1	FM0	Audio Interface Format				
		0	0	Right justified				
		0	1	Left justified				
		1	0	I <sup>2</sup> S				
		1	1	Reserved				
<b>Reg4</b>		Attenuation Control of DAC2 Left Channel.						
<b>B12~B9</b>	A3, A2, A1, A0	<u>Register Address.</u> To access <b>Reg4</b> , set A3="0", A2="1", A1="0", A0="0".						
<b>B8</b>	LDL2	<u>DAC2 Left Channel Attenuation Data Load Control.</u> When LDL2="0", the attenuation data L2A7~L2A0 are loaded but do not affect the output level until LDL2="1". That is when LDL2="0", the left channel output level remains at the previous attenuation level; and when LDL2="1", the left channel output level becomes affected by L2A7~L2A0. Either LDL2 or LDR2 is set to "1", the L and R channel attenuation data become effective simultaneously.						
<b>B7~B0</b>	L2A7~L2A0	<u>DAC2 Left Channel Attenuation Data.</u> Attenuation level = 20*log (L2A[7:0]/256)dB.						
<b>Reg5</b>		Attenuation Control of DAC2 Right Channel.						
<b>B12~B9</b>	A3, A2, A1, A0	<u>Register Address.</u> To access <b>Reg5</b> , set A3="0", A2="1", A1="0", A0="1".						
<b>B8</b>	LDR2	<u>DAC2 Right Channel Attenuation Data Load Control.</u> When LDR2="0", the attenuation data R2A7~R2A0 are loaded but do not affect the output level until LDR2="1". That is when LDR2="0", the right channel output level remains at the previous attenuation level; and when LDR2="1", the right channel output level becomes affected by R2A7~R2A0. Either LDL2 or LDR2 is set to "1", the L and R channel attenuation data become effective simultaneously.						
<b>B7~B0</b>	R2A7~R2A0	<u>DAC2 Right Channel Attenuation Data.</u> Attenuation level = 20*log (R2A[7:0]/256)dB.						
<b>Reg6</b>		Attenuation Control of DAC3 Left Channel.						
<b>B12~B9</b>	A3, A2, A1, A0	<u>Register Address.</u> To access <b>Reg6</b> , set A3="0", A2="1", A1="1", A0="0".						

<b>B8</b>	LDL3	<u>DAC3 Left Channel Attenuation Data Load Control.</u> When LDL3="0", the attenuation data L3A7~L3A0 are loaded but do not affect the output level until LDL3="1". That is when LDL3="0", the left channel output level remains at the previous attenuation level; and when LDL3="1", the left channel output level becomes affected by L3A7~L3A0. Either LDL3 or LDR3 is set to "1", the L and R channel attenuation data become effective simultaneously.		
<b>B7~B0</b>	L3A7~L3A0	<u>DAC3 Left Channel Attenuation Data.</u> Attenuation level = $20 \cdot \log(L3A[7:0]/256)$ dB.		
<b>Reg7</b>		Attenuation Control of DAC3 Right Channel.		
<b>B12~B9</b>	A3, A2, A1, A0	<u>Register Address.</u> To access <b>Reg7</b> , set A3="0", A2="1", A1="1", A0="1".		
<b>B8</b>	LDR3	<u>DAC3 Right Channel Attenuation Data Load Control.</u> When LDR3="0", the attenuation data R3A7~R3A0 are loaded but do not affect the output level until LDR3="1". That is when LDR3="0", the right channel output level remains at the previous attenuation level; and when LDR3="1", the right channel output level becomes affected by R3A7~R3A0. Either LDL3 or LDR3 is set to "1", the L and R channel attenuation data become effective simultaneously.		
<b>B7~B0</b>	R3A7~R3A0	<u>DAC3 Right Channel Attenuation Data.</u> Attenuation level = $20 \cdot \log(R3A[7:0]/256)$ dB.		
<b>Reg8</b>		Simultaneous Attenuation Control for All Channels.		
<b>B12~B9</b>	A3, A2, A1, A0	<u>Register Address.</u> To access <b>Reg8</b> , set A3="1", A2="0", A1="0", A0="0".		
<b>B8</b>	LDS	<u>Simultaneous Attenuation Data Load Control.</u> When LDS="0", the attenuation data are loaded but the output level of all channels remain at the previous attenuation level until LDS is set to "1". When LDS="1", all channels output levels become affected by SA7~SA0.		
<b>B7~B0</b>	SA7~SA0	<u>Simultaneous Attenuation Data for All Channels.</u> Attenuation level = $20 \cdot \log(SA[7:0]/256)$ dB.		
<b>Reg9</b>		DAC Multi-function Control		
<b>B12~B9</b>	A3, A2, A1, A0	<u>Register Address.</u> To access <b>Reg9</b> , set A3="1", A2="0", A1="0", A0="1".		
<b>B8</b>	Res	Reserved and should be set to "0".		
<b>B6~B5</b>	SC1 ~ SC0	<u>System Clock Control.</u>		
		SC1	SC0	System Clock
		0	0	SCKI ÷ 1
		0	1	SCKI ÷ 2
		1	0	SCKI ÷ 2
		1	1	SCKI ÷ 4
<b>B3~B2</b>	SF1 ~ SF0	<u>De-emphasis Sampling Rate Selection.</u>		
		SF1	SF0	De-emphasis Sampling Rate
		0	0	Reserved
		0	1	32kHz group
		1	0	48kHz group
		1	1	44.1kHz group
<b>B1~B0</b>	MC1 ~ MC0	<u>Modulator Over-sampling Control.</u>		
		MC1	MC0	Modulator Over-sampling Rate
		0	0	64X
		0	1	128X
		1	0	32X
		1	1	Reserved

## Power-On Reset

When power is first up, a reset function is automatically performed. Refer to the **Table-8** below for reset states of the ten registers. During the first 3,072 cycles of the system clock after reset, control data can be loaded to the ten registers and at the same time the output is forced to bipolar zero state. After 3,072 cycles of system clock, a “Low” to “High” at ML (pin12) will initiate programming.

**Table-8 Register Reset States**

Register Name	State
<b>Reg0</b>	0000 0001 1111 1111
<b>Reg1</b>	0000 0011 1111 1111
<b>Reg2</b>	0000 0101 0010 0000
<b>Reg3</b>	0000 0110 0010 0000
<b>Reg4</b>	0000 1001 1111 1111
<b>Reg5</b>	0000 1011 1111 1111
<b>Reg6</b>	0000 1101 1111 1111
<b>Reg7</b>	0000 1111 1111 1111
<b>Reg8</b>	0001 0001 1111 1111
<b>Reg9</b>	0001 0010 0000 0000

## Audio Input Format

The register bits, FM1 and FM0 of **Reg3** together determine the audio input data format as shown in the following table:

**Table-9 Audio Interface Format Control**

FM1	FM0	Audio Input Format Selected
0	0	Right justified
0	1	Left justified
1	0	I <sup>2</sup> S
1	1	Reserved

## Audio Input Word Length

The register bits, IW1 and IW0 of **Reg3** together determine the audio input data word length as shown in the following table:

**Table-10 Audio Input Word Length Control**

IW1	IW0	Audio Input Word Length Selected
0	0	16 bit
0	1	20 bit
1	0	24 bit
1	1	32 bit

## Digital Volume Control

**Reg0** [L1A7: L1A0] and **Reg1** [R1A7: R1A0] control the left and right channel attenuation for DAC1.

**Reg4** [L2A7: L2A0] and **Reg5** [R2A7: R2A0] control the left and right channel attenuation for DAC2.

**Reg6** [L3A7: L3A0] and **Reg7** [R3A7: R3A0] control the left and right channel attenuation for DAC3.

**Reg8** [SA7: SA0] controls the attenuation for all channels. The attenuation level for DAC is equal to  $20 \cdot \log(\text{data}/256)$  dB. The attenuation level varies linearly with the register bit value.

## Power-On Reset

When power is first up, a reset function is automatically performed. Refer to the **Table-8** below for reset states of the ten registers. During the first 3,072 cycles of the system clock after reset, control data can be loaded to the ten registers and at the same time the output is forced to bipolar zero state. After 3,072 cycles of system clock, a “Low” to “High” at ML (pin12) will initiate programming.

**Table-8 Register Reset States**

Register Name	State
<b>Reg0</b>	0000 0001 1111 1111
<b>Reg1</b>	0000 0011 1111 1111
<b>Reg2</b>	0000 0101 0010 0000
<b>Reg3</b>	0000 0110 0010 0000
<b>Reg4</b>	0000 1001 1111 1111
<b>Reg5</b>	0000 1011 1111 1111
<b>Reg6</b>	0000 1101 1111 1111
<b>Reg7</b>	0000 1111 1111 1111
<b>Reg8</b>	0001 0001 1111 1111
<b>Reg9</b>	0001 0010 0000 0000

## Audio Input Format

The register bits, FM1 and FM0 of **Reg3** together determine the audio input data format as shown in the following table:

**Table-9 Audio Interface Format Control**

FM1	FM0	Audio Input Format Selected
0	0	Right justified
0	1	Left justified
1	0	I <sup>2</sup> S
1	1	Reserved

## Audio Input Word Length

The register bits, IW1 and IW0 of **Reg3** together determine the audio input data word length as shown in the following table:

**Table-10 Audio Input Word Length Control**

IW1	IW0	Audio Input Word Length Selected
0	0	16 bit
0	1	20 bit
1	0	24 bit
1	1	32 bit

## Digital Volume Control

**Reg0** [L1A7: L1A0] and **Reg1** [R1A7: R1A0] control the left and right channel attenuation for DAC1.

**Reg4** [L2A7: L2A0] and **Reg5** [R2A7: R2A0] control the left and right channel attenuation for DAC2.

**Reg6** [L3A7: L3A0] and **Reg7** [R3A7: R3A0] control the left and right channel attenuation for DAC3.

**Reg8** [SA7: SA0] controls the attenuation for all channels. The attenuation level for DAC is equal to  $20 \cdot \log(\text{data}/256)$  dB. The attenuation level varies logarithmically with the register bit value.

**Table-11 Attenuation Level Control**

Control Data	DAC Attenuation
Ffh	0 dB
Feh	-0.068 dB
-----	-----
01h	-48.16 dB
00h	Mute

In addition setting the ATC bit of **Reg2** can control the outputs of left and right channel of DAC to be attenuated independently or simultaneously. Following Table-11 shows their setting.

**Table-12 Left/Right Attenuation Control**

Register Bit Name	Logic Value	0	1
	ATC DAC Attenuation Control		Left Channel Controlled by AL[7:0] Right Channel Controlled by AR[7:0]

### Soft Mute Function

Soft mute function is implemented for all DAC channels in both hardware mode and software mode. It takes  $256/f_s$  seconds for DAC to soft mute its output; therefore the time needed to soft mute the DAC depends on the sampling rate used. The Digital Attenuation bits of **Reg0**, **Reg1**, and **Reg4 ~ Reg7** can be used to mute each DAC output independently.

**Table-13 Soft Mute Function Control**

MUT	Soft Mute Function
0	OFF
1	ON

### Infinite Zero Detect Function

The zero detect feature is used to avoid noise caused by DC level input. The **Reg2** bit 2 (OPE) and **Reg2** bit 4 (IZD) controls the infinite zero detect function. When OPE = "1", the output of DAC is forced to bipolar zero, which is equivalent to output MUTE, regardless of any data inputs. When OPE = "0", the zero detect function is controlled by IZD. When OPE = "0", IZD = "1", the zero detect feature is enabled. At this time if the digital audio input data are continuously zero for 65,536 BCK cycles, the output will be forced to bipolar zero. If the input data are not zero, the DAC will convert the non-zero data. On the other hand the zero detect function can be disabled by setting OPE = "0", IZD = "0", and an external mute circuit can be implemented at user's choice.

### De-emphasis Function and De-emphasis Frequency Response Selection

The register bit DEM of **Reg2** decides if the de-emphasis function is enabled. **Table-14** shows the control of DEM bit:

**Table-14 De-emphasis Function Control**

DEM	De-emphasis Function
0	OFF
1	ON

The setting of register bit SF1 and SF0 of **Reg9** determines the sampling frequency for De-emphasis.

**Table-15** shows the bit setting combinations of SF1 and SF0 and their corresponding De-emphasis



sampling frequencies. The resulted frequency response is also provided in the graphs below. To enable the de-emphasis function, the DEM is set to "1" and followed by the proper setting of the SF1 and SF0.

**Table-15 De-emphasis Sampling Frequency Control**

SF1	SF0	De-emphasis Sampling Frequency
0	0	OFF
0	1	32 KHz
1	0	48 KHz
1	1	44.1KHZ

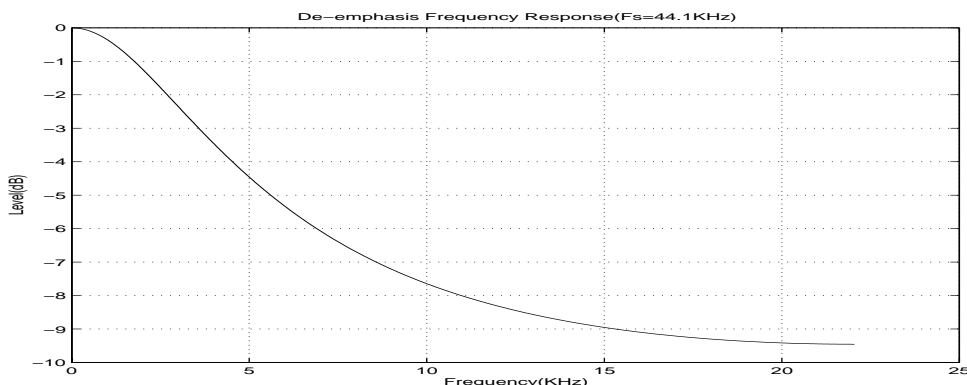

De-emphasis at 44.1KHz Sampling Frequency

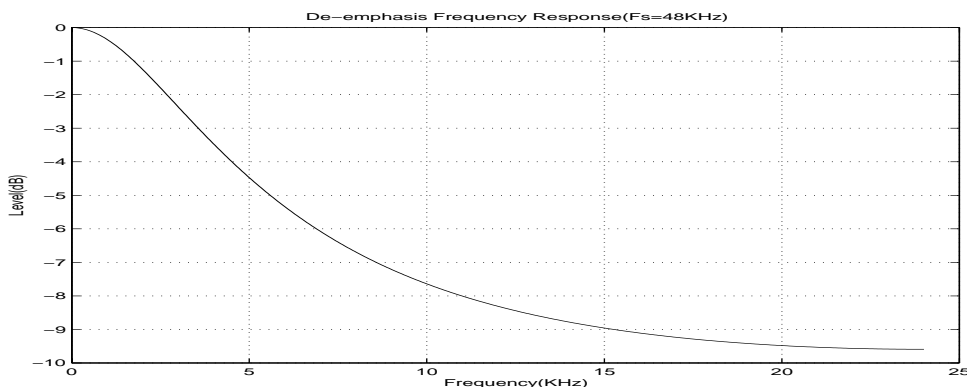

De-emphasis at 48KHz Sampling Frequency

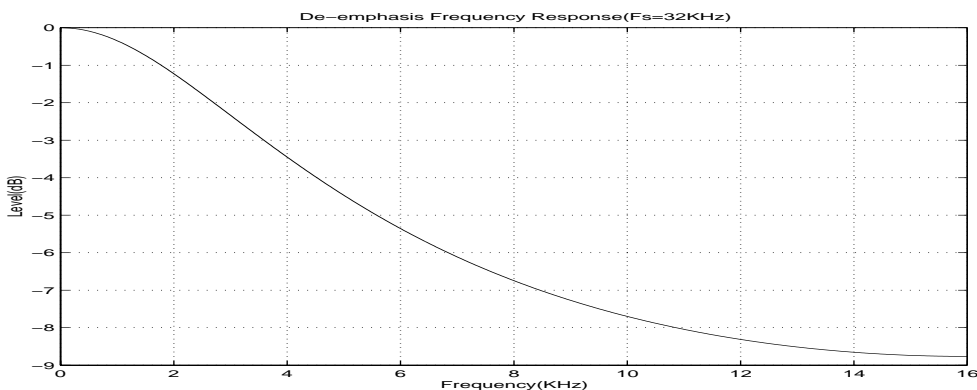

De-emphasis at 32KHz Sampling Frequency

**Modulator Over-sampling Control**

When the sampling rate SRCIN is below 16KHz, it is recommended to increase the over-sampling rate of modulator to 128X by setting the register bit MC1 of **Reg9** = "0" and register bit MC0 of **Reg9** = "1" to improve the dynamic performance of the DA converter.

# Application Considerations

## Application Circuit

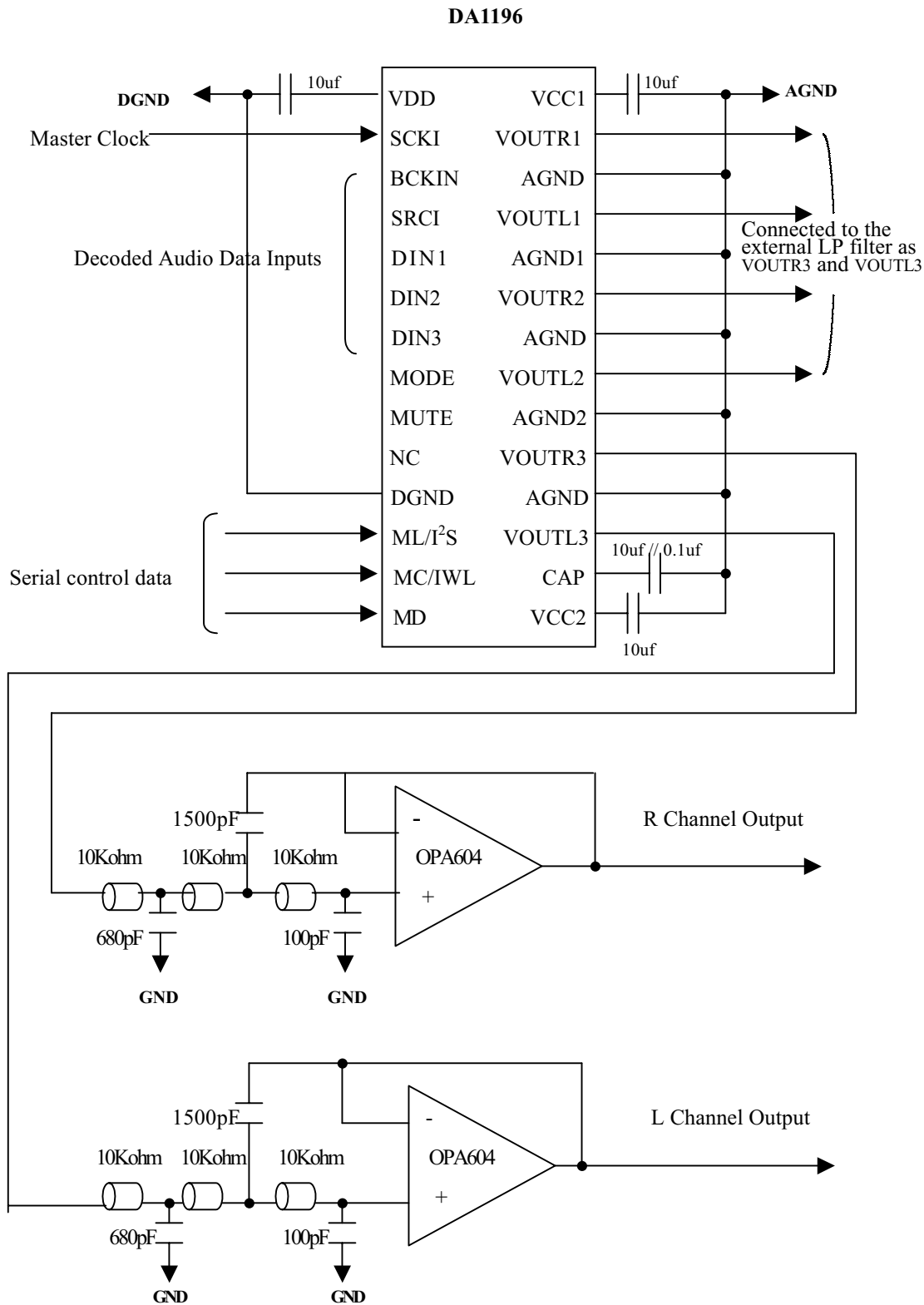

VCC1, VCC2, VDD all connected to 5V/3.3V analog power supply.

DA1196 has separate pins for two analog power supplies and digital power supply. It is recommended to connect the power pins together to the analog power supply and ground pins to the analog ground plane at locations near by the physical pins.

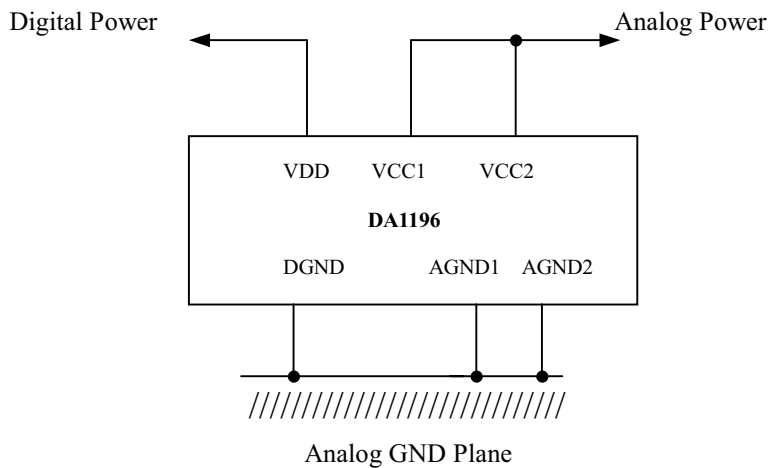

### Output Filtering

The internal low pass filter has 3dB bandwidth at 100kHz. To limit out of band noise, an external 3<sup>rd</sup> order filter as shown in the application circuit diagram is recommended, especially when the chip is to drive a wide band amplifier.

# Package Drawing No. 128-SS

Model	Package	Package Drawing No.
DA1196	28 pin SSOP	128-SS

Package outline drawing is shown as below:

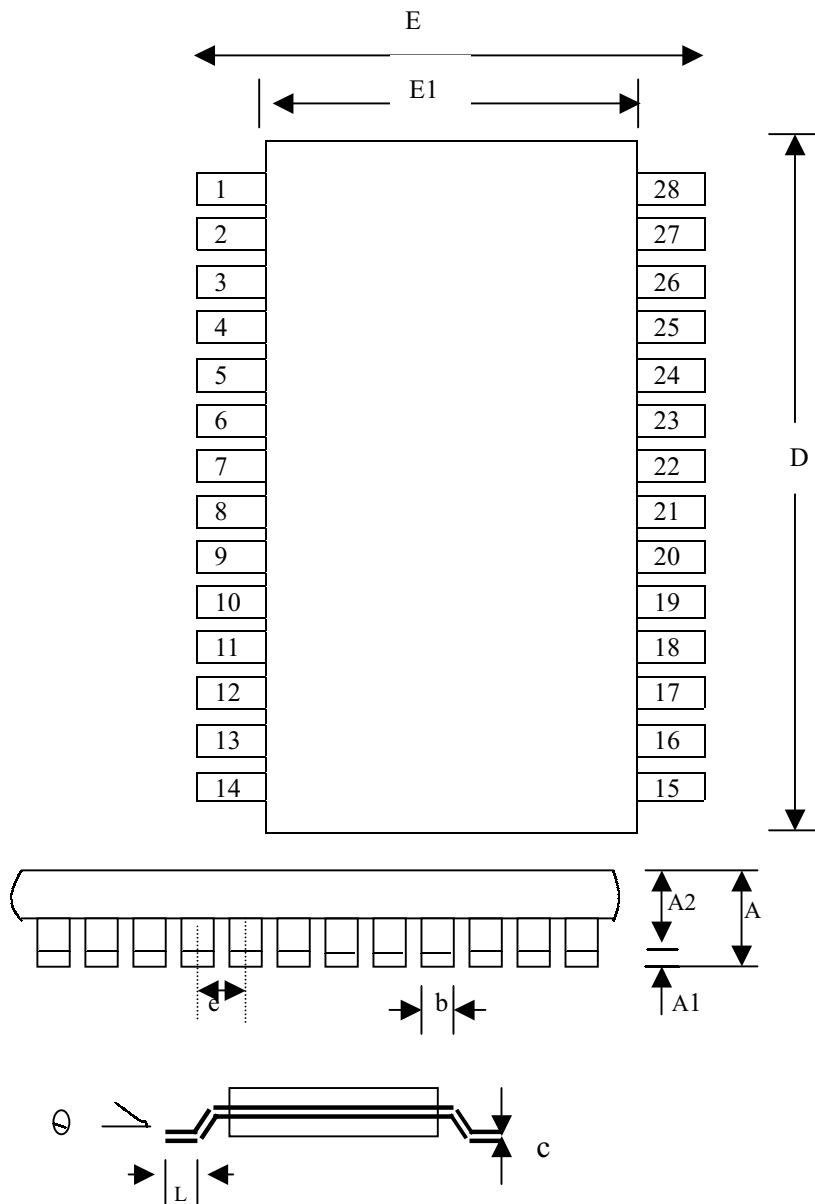

Symbols	Dimensions in millimeters			Dimensions in inches		
	Min	Nom	Max	Min	Nom	Max
A	----	----	2.00	----	----	0.079
A1	0.05	----	----	0.002	----	----
A2	----	1.75	----	----	0.069	----
b	0.22	0.30	0.38	0.0086	0.012	0.015
c	0.13	0.15	0.20	0.0051	0.006	0.0079
D	10.08	10.20	10.34	0.397	0.402	0.407
E	7.40	7.80	8.20	0.291	0.307	0.323
E1	5.00	5.30	5.60	0.197	0.209	0.220
e	----	0.65	----	----	0.0256	----
L	0.56	0.75	0.97	0.022	0.030	0.037
θ	----	4°	8°	----	4°	8°